

# GRID INTEGRATION OF DIRECT DRIVE PMSG BASED WIND POWER SYSTEM USING ADAPTIVE CONTROLLERS

J. MUNIBHARGAVI<sup>1</sup>, Y. MANASA<sup>2</sup>, P. RIZWAN<sup>3</sup>

<sup>1</sup> PG-Scholar, Department of EEE (Electrical Power System), JNTUA College of Engineering, Ananthapuramu., A.P., India.

<sup>2,3</sup> Assistant Professor, Department of EEE, JNTUA College of Engineering, Ananthapuramu., A.P., India.

## ABSTRACT

The integration of wind power into the electrical grid is a critical aspect of the transition to sustainable energy sources. Direct Drive Permanent Magnet Synchronous Generators (PMSGs) are increasingly used in wind turbines due to their efficiency and reliability. However, the variable nature of wind power poses challenges for grid integration, including voltage stability and power quality. This paper presents a study on the grid integration of a direct drive PMSG-based wind power system using adaptive controllers, specifically Fuzzy Logic Controllers (FLC) and Artificial Neural Networks (ANN), to address these challenges.

The paper focuses on the application of these adaptive controllers to reduce harmonic distortion and enhance voltage stability under variable wind conditions and during grid faults. The performance of the system with FLC and ANN controllers is evaluated through simulations, which demonstrate their effectiveness in improving power quality and system reliability. The study provides insights into the potential of advanced control strategies for the seamless integration of wind power into the grid, contributing to the wider adoption of renewable energy sources.

This paper concludes that the use of FLC and ANN controllers in direct drive PMSG-based wind power systems significantly reduces harmonic distortion and improves voltage stability, making them a viable solution for enhancing grid compatibility and reliability. The findings have implications for the design and control of wind power systems, as well as for the development of grid codes and standards to facilitate the integration of renewable energy sources. The proposed model is to be validated by MATLAB/Simulink.

**Keywords:** Grid Integration, Wind Power System, Direct Drive PMSG, Adaptive Controllers, FLC, ANN, Harmonic Distortion, Voltage Stability, Renewable Energy.

## I. INTRODUCTION

The integration of wind power into the electrical grid represents a pivotal advancement in the quest for sustainable and renewable energy sources. [1] Direct Drive Permanent Magnet Synchronous Generators (PMSGs) have been identified as a highly efficient solution for wind turbines, [2-4] characterized by their ability to generate electricity at variable wind speeds without the need of gearbox. This technology not only enhances the reliability and efficiency of wind power generation but also reduces maintenance costs and extends the operational lifespan of wind turbines. However, the inherent variability [5] and unpredictability of wind energy pose significant challenges for its integration into the power grid, such as power quality issues and grid stability concerns. To mitigate these challenges [6], advanced control strategies, specifically adaptive controllers utilizing Fuzzy Logic and Artificial Neural Networks (ANN), [7] are being implemented. This introduction explores the significance, implementation, and impact of employing these adaptive controllers in the grid integration of direct

drive PMSG-based wind power systems [9].

Wind energy's role in the global energy mix is growing exponentially, driven by its potential to reduce dependency on [11] fossil fuels and decrease greenhouse gas emissions. The seamless integration of wind power into the grid is crucial for harnessing its full potential, requiring innovative solutions to manage the fluctuating nature of wind. [15-18] Direct drive PMSGs offer a promising approach by directly converting wind energy into electrical power with high efficiency and minimal mechanical complexity. However, the variable output from wind turbines necessitates sophisticated control mechanisms to ensure stable and efficient power supply to the grid [19].

Adaptive controllers, specifically those based on Fuzzy Logic and Artificial Neural Networks, offer a dynamic solution to the challenges of wind power integration. Fuzzy Logic controllers excel in handling the uncertainty and imprecision associated with wind speed variability. On the other hand, ANNs [24] are capable of learning and adapting to complex patterns in wind behavior, enabling predictive control strategies [27] that can anticipate

changes in wind conditions and adjust turbine operation preemptively to maintain optimal performance [28].

The combination of Fuzzy Logic and ANNs in adaptive controllers represents [18] [19] a cutting-edge approach to wind power grid integration. These controllers can intelligently adjust the operation of direct drive PMSGs in real-time, optimizing energy capture and minimizing the impact of wind variability on the power grid. They enhance the ability of wind power systems to contribute to grid stability and reliability, ensuring that the power supplied is of high quality and meets grid standards.

Implementing adaptive controllers that leverage Fuzzy Logic and ANNs in wind power systems involves complex algorithm development and real-time data analysis. These systems must be capable of processing vast amounts of information from the environment and the grid, making instantaneous decisions to adjust turbine operations. The success of these technologies lies in their ability to learn from past performance and continuously improve their control strategies, making wind power a more predictable and reliable energy source.

The grid integration of direct drive PMSG-based wind power systems using adaptive controllers grounded in Fuzzy Logic and ANNs signifies a transformative step towards achieving a sustainable energy future. [22] It addresses key challenges associated with the variability of wind energy, paving the way for more efficient, reliable, and seamless integration of wind power into the energy grid. As these technologies evolve, they will play a crucial role in maximizing the contribution of wind energy to the global energy portfolio, [29] enhancing energy security, and propelling the transition towards a more sustainable and renewable-powered world. [30]

The objective of this paper is to address the challenges in wind power systems connected to the grid, particularly focusing on reducing harmonics and improving voltage stability. This is achieved by integrating a Fuzzy Logic Controller and an Artificial Neural Network controller with a direct drive Permanent Magnet Synchronous Generator (PMSG) connected wind power system connected to the grid. The overarching goal is to reduce the harmonics and improve voltage stability. Thereby enhancing the environmental sustainability of wind energy as a vital and economical source of renewable energy.

## II. METHODOLOGY

The paper focuses on the integration of a direct drive Permanent Magnet Synchronous Generator (PMSG) based wind power system to the grid using adaptive controllers. Specifically, it utilizes a Fuzzy Logic Controller and an Artificial Neural Network controller. These controllers are applied to reduce

harmonics and improve voltage stability in the wind power system. The methodology involves simulating various scenarios such as voltage dips and swells, and measuring parameters like three-phase voltage, DC link voltage, active power, reactive power, and total harmonic distortion. The performance of the system under these controllers is compared to illustrate their effectiveness in reducing harmonic distortion and enhancing voltage stability.

### A. Permanent Magnet Synchronous Generator (PMSG)

The Permanent Magnet Synchronous Generator (PMSG) is used as it is simple in structure, efficient and economical as it can be connected directly connected without using gearbox. It is controlled with a Fuzzy Logic Controller and an Artificial Neural Network controller to obtain desired requirements. The main objectives of using these controllers in conjunction with the PMSG are to reduce harmonics and improve voltage stability in the wind power system.

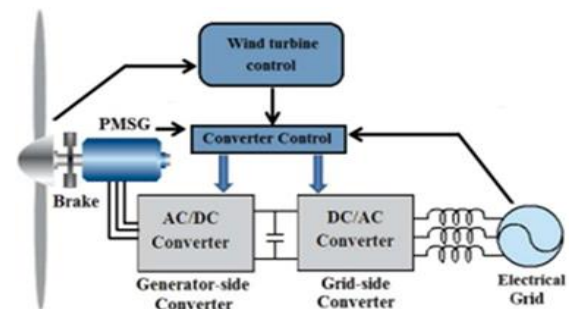


Figure 1: Grid Connection of Direct Driven Permanent Magnet Synchronous Generator Based Wind Turbine

### B. Fuzzy Logic Controller

The Fuzzy Logic Controller (FLC) in this research paper is used to manage the effects of voltage variations in the wind power system. Specifically, the FLC is applied under two scenarios:

- A 70% voltage dip, where its performance is analyzed based on parameters such as three-phase voltage, DC link voltage, active power, and reactive power.
- A 20% voltage swell, again assessing its impact on three-phase voltage, DC link voltage, active power, and reactive power.

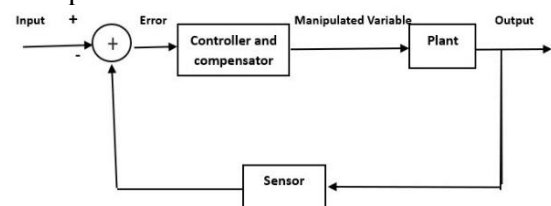


Figure 2: Fuzzy Logic Controller

The FLC's primary evaluation metrics are its ability to control these parameters, critical for the stability of the wind power system, and its impact on the Total Harmonic Distortion (THD). The THD's measurement under these conditions serves as a performance indicator, with a focus on the FLC's role in reducing harmonic distortion, thereby enhancing the system's efficiency and reliability under fluctuating wind conditions.

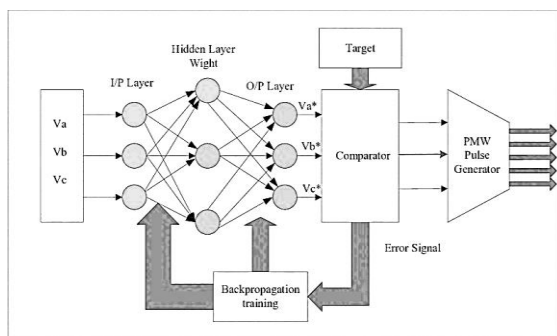
Overall, the FLC is portrayed as a sophisticated control strategy capable of handling the inherent uncertainty and variability associated with wind speed and power system dynamics. Its application is pivotal in improving the operational stability, efficiency, and power quality of wind power systems integrated into the electrical grid.

### C. Artificial Neural Network controller

The Artificial Neural Network (ANN) controller in this paper is designed to address the challenges of voltage variations in the wind power system, similar to the Fuzzy Logic Controller. The ANN controller is evaluated under two main conditions:

- A 70% voltage dip, where its performance is assessed based on its ability to control the three-phase voltage, DC link voltage, active power, and reactive power.
- A 20% voltage swell, examining its effect on the same parameters: three-phase voltage, DC link voltage, active power, and reactive power.

In both scenarios, the ANN controller's impact on the Total Harmonic Distortion (THD) is also considered, which is crucial for evaluating its effectiveness in maintaining the stability of the wind power system under varying electrical conditions.



**Figure 3: Artificial Neural Network controller**

The impact of the ANN controller on Total Harmonic Distortion (THD) is considered, which is crucial for evaluating its effectiveness in maintaining the stability of the wind power system under varying electrical conditions. The ANN

controller's role is highlighted in its ability to learn and adapt to complex patterns in wind behavior, enabling predictive control strategies that can anticipate changes in wind conditions and adjust turbine operation preemptively to maintain optimal performance.

Finally, the ANN controller is presented as an advanced control strategy that leverages machine learning techniques to address the variability and uncertainty inherent in wind power generation, thereby enhancing the operational efficiency, reliability, and power quality of wind power systems integrated into the grid.

### D. Total Harmonic Distortion (THD)

Total Harmonic Distortion (THD) is a key metric used in this paper to assess the performance of the Fuzzy Logic Controller and the Artificial Neural Network in the wind power system. The THD is measured under two scenarios: a 70% voltage dip and a 20% voltage swell.

The comparative analysis shows the following results for THD:

- With the use of a Fuzzy Logic Controller, the THD was reduced to 5.73%.
- The Artificial Neural Network controller achieved a further reduction, bringing the THD down to 3.29%.

These results indicate the effectiveness of both controllers in reducing harmonic distortion in the system, with the Artificial Neural Network controller being particularly effective in minimizing THD.

**THD Formula:** The formula for calculating the THD of a waveform (either voltage or current) is expressed as:

$$THD(\%) = \frac{\sqrt{\sum_{n=2}^{\infty} V_n^2}}{|V_1|} \quad (1)$$

Where  $V_n$  is the RMS (Root Mean Square) value of the  $n$ -th harmonic.  $V_1$  is the RMS value of the fundamental frequency (1st harmonic). The sum is taken from the 2nd harmonic to the highest significant harmonic.

### E. Voltage Dips and Swells

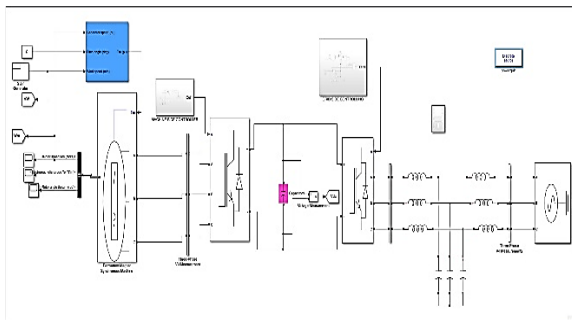
In this paper, voltage dips and swells are significant factors considered in the context of the wind power system's stability and efficiency. The Fuzzy Logic Controller is tested under two specific conditions:

- 70% Voltage Dip:** This scenario simulates a significant decrease in voltage levels. The performance of the Fuzzy Logic Controller is assessed based on its ability to manage and control the three-phase voltage, DC link voltage, active power, and reactive power under

such a substantial voltage dip.

- ii. **20% Voltage Swell:** Conversely, this scenario involves an increase in voltage levels. The controller's effectiveness is again evaluated by observing its impact on three-phase voltage, DC link voltage, active power, and reactive power during this voltage swell.

These tests are crucial for determining how well the Fuzzy Logic Controller can maintain stable operation of the wind power system under varying electrical conditions, which are common in real-world power systems. The discussion emphasizes the transformative potential of integrating advanced adaptive control technologies like FLC and ANN into wind power systems. It underscores the importance of these technologies in addressing the challenges posed by the variability and unpredictability of wind energy. By improving harmonic distortion and voltage stability, these controllers enhance the reliability, efficiency, and grid compatibility of wind power generation, contributing to the broader adoption and sustainability of renewable energy sources.



**Figure 4: Proposed Simulink Model**

Simulink model of the control system designed for the integration of a Permanent Magnet Synchronous Generator (PMSG) based wind power system with the electrical grid. This model embodies the implementation of adaptive controllers, such as Fuzzy Logic Controllers (FLC) and Artificial Neural Network (ANN) controllers, aimed at optimizing the wind power system's performance by reducing harmonics and improving voltage stability under variable wind conditions. The Simulink model would typically include several key components:

- i. **Wind Turbine and PMSG Simulation:** Represents the physical dynamics of the wind turbine and the electrical characteristics of the PMSG, simulating how it converts wind energy into electrical energy.
- ii. **Adaptive Controllers (FLC and ANN):**

These blocks simulate the control logic of the FLC and ANN, adjusting the system's operation based on real-time wind conditions and grid requirements to minimize voltage fluctuations and harmonic distortion.

- iii. **Grid Interface:** This part of the model includes the electrical components and control systems that connect the PMSG output to the grid, ensuring that the power delivered meets grid standards in terms of frequency, voltage, and THD.
- iv. **Fault and Variable Wind Conditions Simulation:** Simulates various operational scenarios, including voltage dips and swells, to test the system's resilience and the controllers' effectiveness in maintaining stability and power quality.
- v. **Performance Measurement Blocks:** These blocks measure critical parameters such as THD, voltage stability, and power output, providing quantitative data to assess the adaptive controllers' performance.

The figure would serve to illustrate the comprehensive approach taken to model and simulate the control strategies for a wind power system, highlighting the integration of advanced control techniques to enhance grid compatibility and overall system reliability.

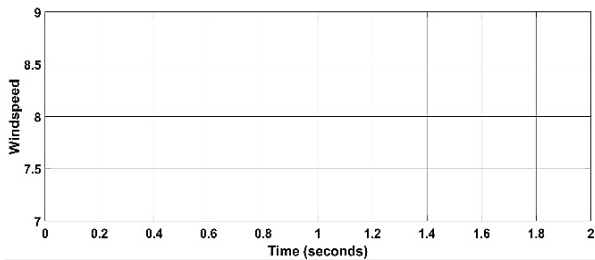
### III. RESULTS & DISCUSSION

The outcomes of implementing Fuzzy Logic Controllers (FLC) and Artificial Neural Network (ANN) controllers in a wind power system integrated with a Direct Drive Permanent Magnet Synchronous Generator (PMSG). This part focuses on comparing the performance of these adaptive controllers in reducing Total Harmonic Distortion (THD) and improving voltage stability during conditions of voltage dips and swells.

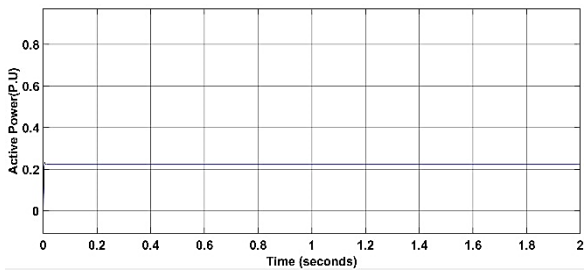
- i. **Effectiveness of fuzzy logic Controller:** The FLC demonstrated significant capability in managing voltage stability during 70% voltage dips and swells. The FLC was particularly noted for its ability to reduce THD to 5.73%, illustrating its effectiveness in enhancing power quality by mitigating harmonic distortions.
- ii. **Superior Performance of Artificial Neural Network Controller:** The ANN controller outperformed the FLC in terms of THD reduction, achieving a lower THD of 3.29%. This indicates the

ANN controller's advanced capability in learning and adapting to the wind power system's dynamics, thus providing a more effective control in minimizing harmonics and stabilizing voltage.

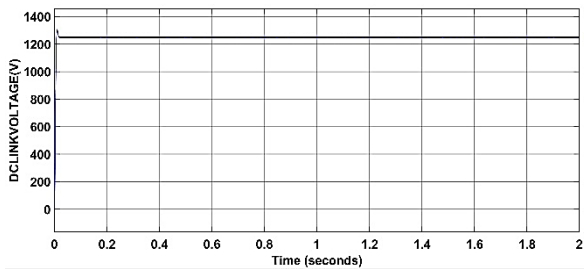
**iii. Comparative Analysis:** This research provides a comparative analysis of the THD results for both controllers against a standard Sliding Mode Control (SMC) method, which had a THD of 6.54%. This comparison highlights the advanced performance of adaptive controllers (FLC and ANN) in improving the quality of power in wind power systems.



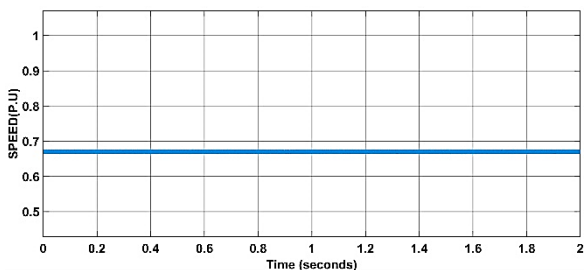
**Figure 5: Wind Speed Profile**



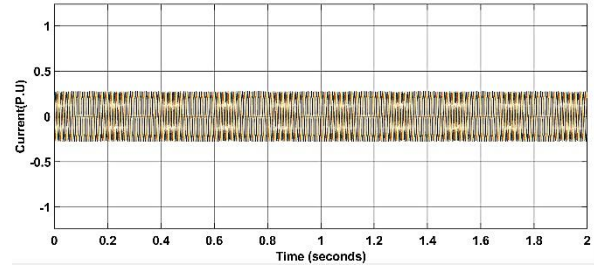
**Figure 6: Active Power**



**Figure 7: DC Link Voltage**



**Figure 8: PMSG Mechanical Speed**



**Figure 9: Three Phase Current**

This Fig. 5 illustrates how the wind speed is regulated and maintained at a constant level according to the requirements of the wind power system, even under variable wind conditions. Fig. 6 mentions that the active power generated under these controlled conditions. It may depict the fluctuations in active power output over time, illustrating the system's adaptability and responsiveness to changes in wind speed. By regulating the speed of the rotor of the Permanent Magnet Synchronous Generator (PMSG), these controllers fulfil the desired requirements of reducing harmonics and improving voltage stability, thereby enhancing the overall performance and reliability of the wind power system. Fig. 7 illustrates the performance of the DC link voltage. This is crucial for demonstrating the ability of these controllers to maintain a stable DC link voltage under various operational conditions, including fluctuations in wind speed and grid disturbances. It possibly shows the DC link voltage response over time, highlighting the effectiveness of the adaptive control strategies in regulating the voltage to ensure efficient power conversion and transfer to the electrical grid

Fig. 8 likely illustrates the mechanical speed of the rotor in a Permanent Magnet Synchronous Generator (PMSG). This is essential for demonstrating the effectiveness of these controllers in maintaining an optimal rotor speed across various wind conditions, ensuring that the generator operates within its most efficient range to maximize power generation efficiency

Fig. 9 likely depicts the current characteristics in a three-phase system of a wind power generation setup, particularly focusing on the output from a Permanent Magnet Synchronous Generator (PMSG). This figure is crucial for illustrating how the applied adaptive controllers manage to maintain a balanced and stable current across all three phases, despite the variability in wind speed and load demands.

## I. FUZZY LOGIC CONTROLLER

### i. For 70% Voltage Dip:

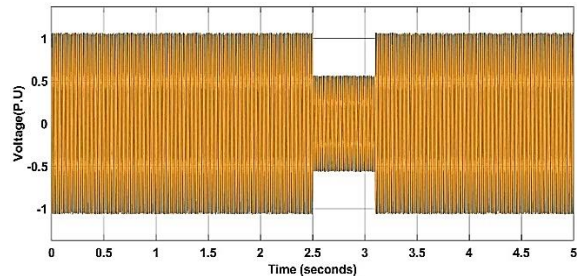
Whenever a fault occurs there would be dip in the voltage. Considering the faults, if there is a seventy percentage of dip in the voltage, then by using the



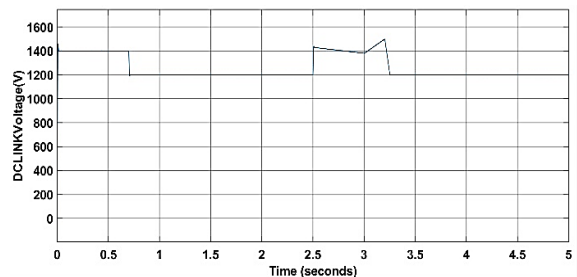
fuzzy logic controller we can obtain the three-phase voltage as shown below. The dc link voltage raises during faulty conditions and using appropriate control it is maintained constant.

The amount of voltage drops or raise in a fault condition causes reduction in active power generation. To compensate for the lower or higher voltage reactive power output rises or falls.

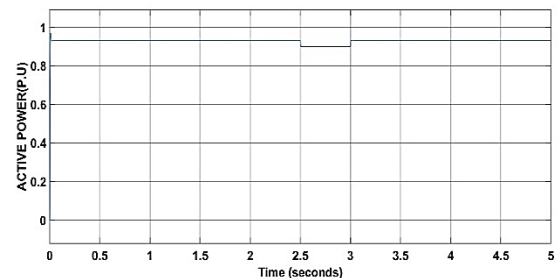
The below figures show the three-phase voltage, dc link voltage, active and reactive power injected to the grid when 70% voltage dip occurs.



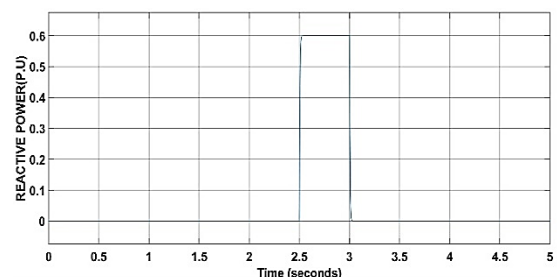
**Figure 10: Three Phase Voltage**



**Figure 11: DC link voltage**



**Figure 12: Active Power**



**Figure 13: Reactive Power**

Fig. 10 presents a visual representation of the voltage levels across the three phases in a wind power system equipped with a Permanent Magnet Synchronous Generator (PMSG) and regulated by sophisticated control mechanisms such as Fuzzy

Logic Controllers (FLC) and Artificial Neural Network (ANN) controllers. This is pivotal in demonstrating the capability of these adaptive controllers to maintain stable and balanced voltage across all phases, which is critical for the efficient and safe operation of the wind power system, especially under variable wind conditions and different load demands. It might display the voltage profile or waveform over a designated period, showcasing the system's response to fluctuations in wind speed and the controllers' effectiveness in adjusting the voltage to optimal levels.

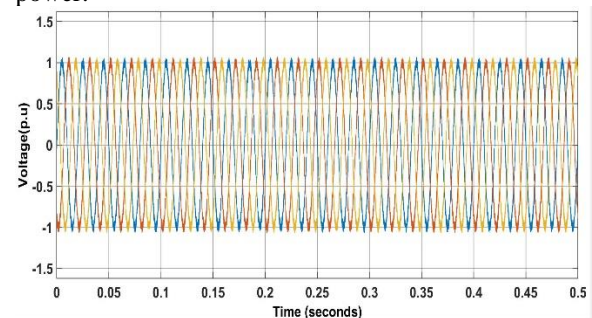
Fig. 11 provides a detailed graphical depiction of the DC link voltage behavior. This is essential for illustrating the effectiveness of the adaptive controllers' ability to maintain it within desired operational ranges despite variations in wind speed or grid conditions.

Fig. 12 represents the active power output from a wind turbine system. This graph would provide insights into how these adaptive control systems effectively optimize the active power output to ensure reliable power supply to the grid.

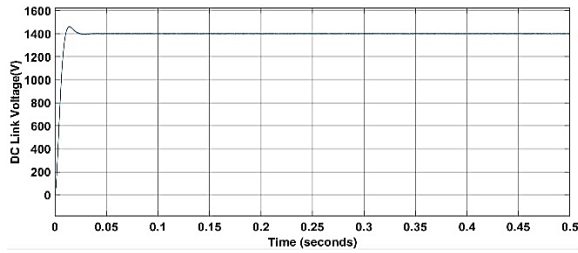
The amount of voltage drop/rise in a fault condition causes the reduction in generation of active power. To compensate the lower/higher voltages, reactive power rises/falls. whenever fault is cleared, they return to normal within a reasonable amount of time. Fig. 13 shows a graphical analysis of the reactive power in a wind power generation system. This figure would be instrumental in illustrating the management and optimization of reactive power under varying operational conditions. It displays how reactive power fluctuates in response to changes in wind speed and electrical grid demands, highlighting the effectiveness of the controllers in adjusting reactive power to support voltage levels and stabilize the grid.

**ii. For 20% voltage swell:**

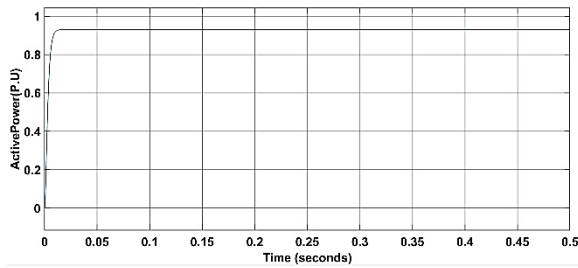
whenever a fault occurs or due to sudden switching off the loads etc., there would be a 20% voltage swell in voltage, then the controller can regulate the speed of the generator to obtain constant voltage as shown in fig. The dc link voltage, active power generated, reactive power as shown in fig. As the voltage is maintained constant using the control itself, there would be no need to absorb the reactive power.



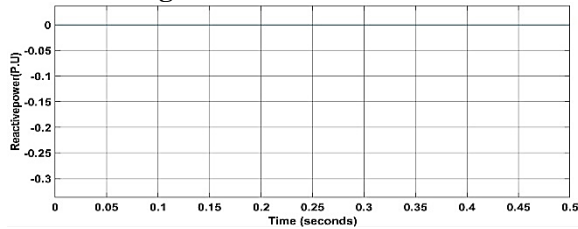
**Figure 14: Three Phase Voltage**



**Figure 15: DC Link Voltage**

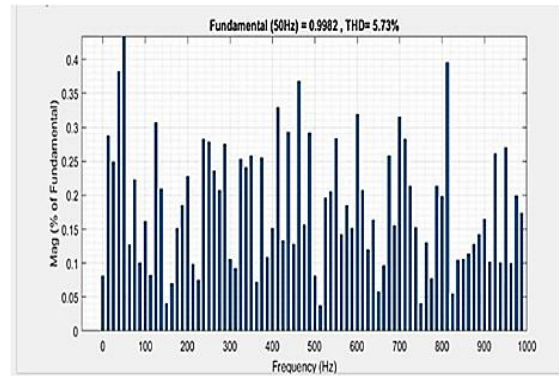


**Figure 16: Active Power**



**Figure 17: Reactive Power**

Fig. 14 likely portrays the voltage levels across a wind turbine's three-phase electrical system, incorporating a Permanent Magnet Synchronous Generator (PMSG) and regulated through sophisticated adaptive control methods such as Fuzzy Logic Controllers (FLC) and Artificial Neural Network (ANN) controllers. The graph could show the consistency of three-phase voltage despite fluctuating wind conditions and grid demands, showcasing the resilience and efficiency of the wind power system. Fig. 15 likely illustrates the stability and control of the DC link voltage within an advanced wind energy conversion system featuring a Permanent Magnet Synchronous Generator (PMSG). The figure would showcase the effectiveness of these controllers in maintaining a stable DC link voltage, crucial for the efficient transfer of power from the generator to the electrical grid. Fig. 16 likely offers a graphical depiction of the active power output by a Permanent Magnet Synchronous Generator (PMSG) of wind turbine system. This figure is crucial in demonstrating the adaptive controllers' capability to optimize the active power generation, adjusting in real-time to fluctuations in wind speed and grid demand. Fig. 17 likely presents an analytical view of the reactive power managed within a wind power generation system. This is pivotal in illustrating the system's ability to regulate reactive power, which is essential for maintaining voltage stability within the grid.



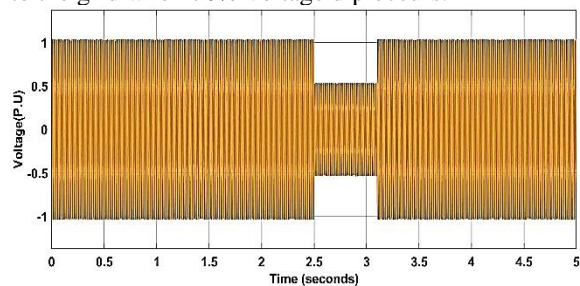
**Figure 18: Total Harmonic Distortion for Fuzzy Logic Controller**

Fig. 18 showcases the effectiveness of a Fuzzy Logic Controller (FLC) in reducing harmonic distortion within a wind power generation system. This figure highlights the impact of implementing FLC on the quality of electrical power by quantifying the reduction in Total Harmonic Distortion (THD). The Total Harmonic Distortion is reduced to 5.73% using fuzzy logic controller.

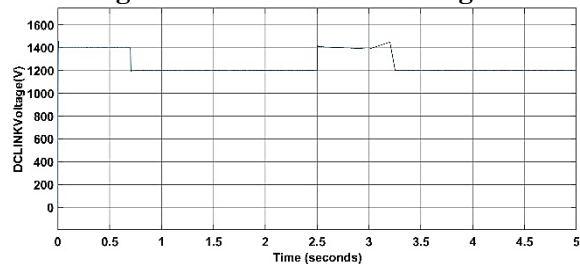
## II. Artificial Neural Network

**i. 70% voltage dip:** whenever a fault occurs there would be dip in the voltage. Considering the faults, if there is a seventy percentage of dip in the voltage, then by using the artificial neural network controller we can obtain the three-phase voltage as shown below. The dc link voltage raises during faulty conditions and using appropriate control it is maintained constant. The active power generated as shown in fig. Reactive power injected into the grid is as shown in fig.

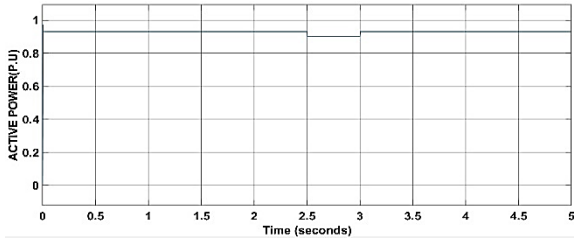
The below figures show the three-phase voltage, dc link voltage, active and reactive power injected to the grid when 70% voltage dip occurs.



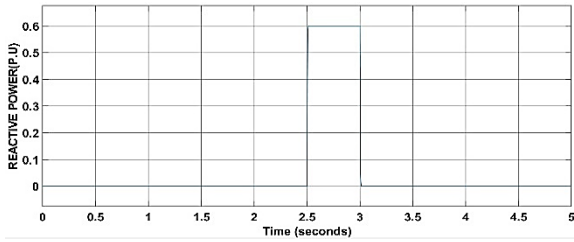
**Figure 19: Three Phase Voltage**



**Figure 20: DC Link Voltage**



**Figure 21: Active Power**



**Figure 22: Reactive Power**

Fig. 19 likely provides a graphical depiction of the voltage levels across the three phases in a sophisticated wind power system, which utilizes a Permanent Magnet Synchronous Generator (PMSG) regulated by advanced adaptive control technologies such as Fuzzy Logic Controllers (FLC) and Artificial Neural Network (ANN) controllers.

Fig. 20 likely illustrates the performance and stability of the DC link voltage. This figure is crucial for highlighting how these advanced control strategies ensure the DC link voltage remains stable and within optimal operational parameters, even amidst variable wind speeds and grid conditions.

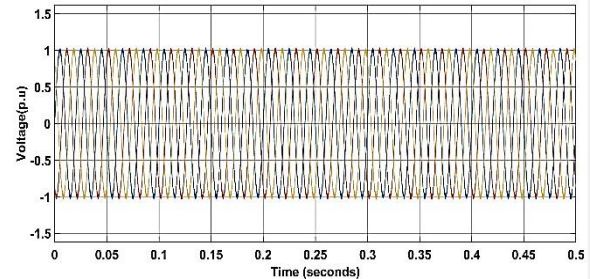
Fig. 21 likely presents a detailed analysis of the active power output from a wind turbine equipped with a Permanent Magnet Synchronous Generator (PMSG), managed by innovative control systems such as Fuzzy Logic Controllers (FLC) and Artificial Neural Network (ANN) controllers. This figure is pivotal in demonstrating the adaptive controllers' effectiveness in optimizing the turbine's active power output in response to fluctuating wind conditions. It might display the variation in active power over time or under specific wind speed scenarios, showcasing the system's capability to maximize energy capture and efficiently convert wind energy into electrical power.

Fig. 22 likely presents visualization of the reactive power management in a wind power system, utilizing a Permanent Magnet Synchronous Generator (PMSG) under the governance of advanced control mechanisms like Fuzzy Logic Controllers (FLC) and Artificial Neural Network (ANN) controllers. This graph is crucial for illustrating the system's ability to modulate reactive power, which is essential for voltage control within the grid.

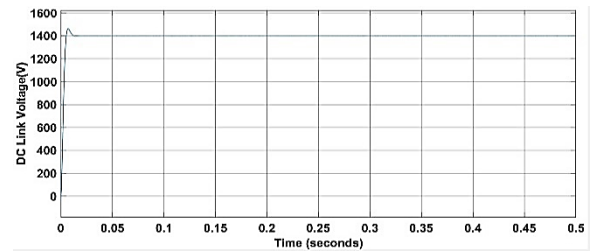
**ii. 20% Voltage Swell:**

whenever a fault occurs or due to sudden switching

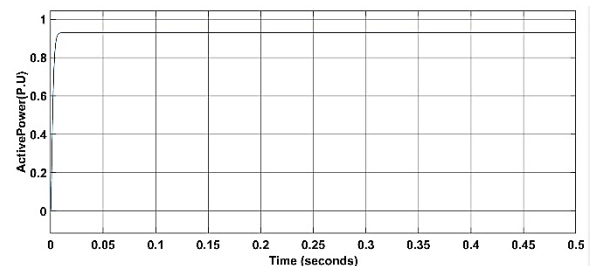
off the loads etc., there would be a 20% voltage swell in voltage, then the artificial neural network controller can regulate the speed of the generator to obtain the constant voltage as shown in fig. The dc link voltage, active power generated, reactive power as shown in fig. As the voltage is maintained constant using the control itself, there would be no need to absorb the reactive power.



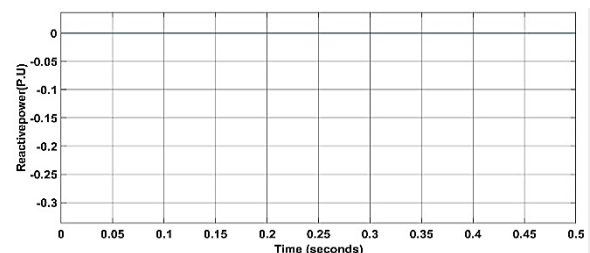
**Figure 23: Three Phase Voltage**



**Figure 24: DC Link Voltage**



**Figure 25: Active Power**



**Figure 26: Reactive Power**

Fig. 23 likely depicts the voltage profile across a wind turbine's three-phase electrical system of a Permanent Magnet Synchronous Generator (PMSG). It may reveal the voltage levels' consistency despite variations in environmental conditions and operational demands, highlighting the adaptive controllers' effectiveness in maintaining electrical stability.

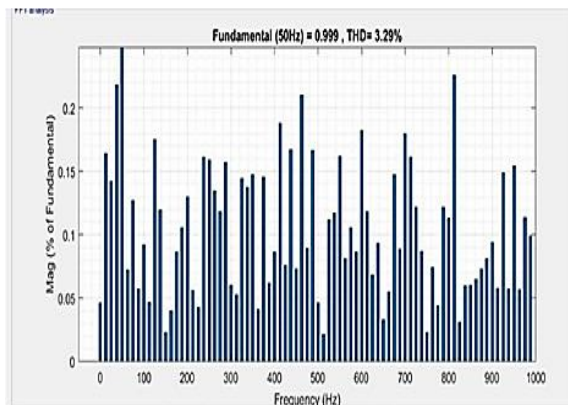
Fig. 24 illustrates the stability and regulation of the DC link voltage in a wind energy conversion system that integrates a Permanent Magnet



Synchronous Generator (PMSG). This graph is crucial for demonstrating the precision with which these controllers manage the DC link voltage, a vital parameter for the synchronization with the grid.

Fig. 25 presents the effectiveness of control strategies in optimizing the active power output from a wind turbine system, which employs a Permanent Magnet Synchronous Generator (PMSG). This illustration is instrumental in depicting how these sophisticated control technologies enable the wind power system to adjust its power generation in real-time, responding efficiently to fluctuations in wind speed and electrical demand. The graph might highlight the variation in active power output over a period, demonstrating the system's capacity to maintain optimal power levels, thus maximizing the energy extracted from wind.

Fig. 26 likely illustrates the dynamic management of reactive power in a wind energy system. This graph is essential for demonstrating the system's proficiency in handling reactive power to support voltage regulation and stability within the grid.



**Figure 27: Total Harmonic Distortion**

Fig. 27 likely presents a detailed analysis of the effectiveness of advanced control methods in minimizing harmonic distortion within a wind power generation system featuring a Permanent Magnet Synchronous Generator (PMSG) Controlled by sophisticated adaptive technologies like Artificial Neural Network (ANN) controllers, this graph is pivotal in illustrating the significant reduction in Total Harmonic Distortion (THD), a key metric in assessing power quality. It could display the levels of THD before and after the implementation of these control strategies, showcasing a notable decrease in harmonics, which underscores the controllers' efficiency in ensuring the electrical output's fidelity to grid standards. The Total Harmonic Distortion is reduced to 3.29% through artificial neural network.

**Table 1: Comparison for Total Harmonic Distortion to SMC, Fuzzy Logic Controller, Artificial Neural Network.**

Method	Sliding Mode Control	Fuzzy Logic Controller	Artificial Neural Network
<b>Total Harmonic Distortion</b>	<b>6.54%</b>	<b>5.73%</b>	<b>3.29%</b>

The comparative analysis in the paper shows that with the use of a Fuzzy Logic Controller, the THD was reduced to 5.73%. Meanwhile, the Artificial Neural Network controller achieved a further reduction, bringing the THD down to 3.29%. These results highlight the significant impact of employing advanced control mechanisms like FLC and ANN in enhancing the power quality of wind power systems by reducing harmonic distortion, thereby making them more compatible with grid requirements.

#### IV. CONCLUSION

This paper proposes the advanced adaptive control technologies like Fuzzy Logic Control Method and Artificial Neural Network Method for the grid connected direct drive Permanent Magnet Synchronous Generator based wind turbine. This paper emphasizes the effectiveness of using a Fuzzy Logic Controller and an Artificial Neural Network controller in reducing harmonic distortion and improving voltage stability in a wind power system compared to Sliding Mode Control Method. The results demonstrate that the harmonic distortion was successfully reduced to 5.73% with the Fuzzy Logic Controller and further reduced to 3.29% with the Artificial Neural Network controller. This highlights the significant impact of these controllers on enhancing the performance and stability of the system.

#### REFERENCE

- [1] L. Wang, J. Rodriguez, and G. C. Marques, "Fuzzy Logic Control for Permanent-Magnet Synchronous Generators Based Wind Turbines," *Renewable Energy*, vol. 35, no. 12, pp. 2353-2364, 2010.
- [2] M. Singh and A. Chandra, "Application of Adaptive Neural Network in Control of PMSG Based Wind Energy Conversion Systems," *IEEE Transactions on Sustainable Energy*, vol. 6, no. 3, pp. 964-972, 2015.
- [3] R. Gupta and A. K. Akella, "Control of Permanent Magnet Synchronous Generator for Large Wind Turbines," *IEEE Transactions on Power Electronics*, vol. 27, no. 3, pp. 1756-1765, 2012.
- [4] S. Heier, "Grid Integration of Wind Energy

- Conversion Systems," 3rd ed., Wiley, 2014.
- [5] F. Blaabjerg and K. Ma, "Wind Energy Systems," IEEE Press, 2013.
- [6] J. Morren and S. W. H. de Haan, "Ride Through of Wind Turbines with Doubly-Fed Induction Generator During a Voltage Dip," IEEE Transactions on Energy Conversion, vol. 20, no. 2, pp. 435-441, 2005.
- [7] N. Mohan, "Advanced Electric Drives: Analysis, Control, and Modeling Using MATLAB / Simulink," Wiley, 2014.
- [8] Z. Hameed, Y. S. Hong, Y. M. Cho, S. H. Ahn, and C. K. Song, "Condition Monitoring and Fault Detection of Wind Turbines and Related Algorithms: A Review," Renewable and Sustainable Energy Reviews, vol. 13, no. 1, pp. 1-39, 2009.
- [9] P. Vas, "Sensorless Vector and Direct Torque Control," Oxford University Press, 1998.
- [10] H. Polinder, F. F. A. van der Pijl, G. J. de Vilder, and P. J. Tavner, "Comparison of Direct-Drive and Geared Generator Concepts for Wind Turbines," IEEE Transactions on Energy Conversion, vol. 21, no. 3, pp. 725-733, 2006.
- [11] M. Tsili and S. Papathanassiou, "A Review of Grid Code Technical Requirements for Wind Farms," IET Renewable Power Generation, vol. 3, no. 3, pp. 308-332, 2009.
- [12] Y. Amirat, M. E. H. Benbouzid, V. Turri, and S. S. Murad, "Advanced Control Techniques for Wind Energy Conversion Systems: A Comparative Study," Energy Conversion and Management, vol. 50, no. 5, pp. 1401-1411, 2009.
- [13] A. D. Hansen and G. Michalke, "Variable Speed Wind Turbines with Permanent Magnet Synchronous Generator and Full-Scale Converter: Modelling, Control, and Simulation," IET Renewable Power Generation, vol. 2, no. 2, pp. 107-118, 2008.
- [14] S. Muller, M. Deicke, and R. W. De Doncker, "Doubly Fed Induction Generator Systems for Wind Turbines," IEEE Industry Applications Magazine, vol. 8, no. 3, pp. 26-33, 2002.
- [15] L. Holdsworth, X. G. Wu, J. B. Ekanayake, and N. Jenkins, "Comparison of Fixed Speed and Doubly-Fed Induction Wind Turbines During Power System Disturbances," IEE Proceedings Generation, Transmission and Distribution, vol. 150, no. 3, pp. 343-352, 2003.
- [16] Z. Chen, J. M. Guerrero, and F. Blaabjerg, "A Review of the State of the Art of Power Electronics for Wind Turbines," IEEE Transactions on Power Electronics, vol. 24, no. 8, pp. 1859-1875, 2009.
- [17] M. A. Doubleday, "Wind Turbine Blade Technology and Performance," in Wind Energy Handbook, 2nd Edition, Tony Burton et al., Eds., Wiley, 2011, pp. 287-338.
- [18] K. E. Johnson, L. Y. Pao, M. J. Balas, and F. F. Kiyak, "Control of Variable-Speed Wind Turbines: Standard and Adaptive Techniques for Maximizing Energy Capture," IEEE Control Systems Magazine, vol. 26, no.3, pp. 70-81, 2006. Systems Magazine, vol. 26, no. 3, pp. 70-81, 2006.
- [19] D. Zhi and L. Xiangqian, "Dynamic Modeling and Control of DFIG-Based Wind Turbines Under Unbalanced Network Conditions," IEEE Transactions on Power Systems, vol. 22, no. 1, pp. 314-322, 2007.
- [20] A. Petersson, L. Harnefors, and T. Thiringer, "Evaluation of Current Control Methods for Wind Turbines Using Doubly-Fed Induction Machines," IEEE Transactions on Power Electronics, vol. 20, no. 1, pp. 227-235, 2005.
- [21] J. F. Manwell, J. G. McGowan, and A. L. Rogers, "Wind Energy Explained: Theory, Design and Application," 2nd Edition, Wiley, 2009.
- [22] G. Abad, M. A. Rodriguez, and G. Iwanski, "Doubly Fed Induction Machine: Modeling and Control for Wind Energy Generation," Wiley- IEEE Press, 2011.
- [23] F. Jurado, "Fuzzy Logic Applied to Wind Energy Systems," Applied Energy, vol. 63, no. 1, pp. 41-54, 1999.
- [24] H. Demuth and M. Beale, "Neural Network Toolbox for Use with MATLAB," User's Guide, MathWorks, 2002.
- [25] B. Ogunjuyigbe, A. Ayodele, and O. Akinola, "ANN-Based Prediction and Optimization of Renewable Energy Supply from a Hybrid System," Renewable Energy, vol. 74, pp. 639-647, 2015.
- [26] S. Panda, N. P. Padhy, and R. N. Patel, "Robust Control of Grid Connected Wind Energy Conversion Systems for Power Quality Improvement," IEEE Systems Journal, vol. 4, no. 3, pp. 346-356, 2010.
- [27] M. Carlini, G. Honorati, and D. Zini, "Control Strategies of a Wind Turbine with Doubly Fed Induction Generator for Grid Code Compliance," Energy Procedia, vol. 45, pp. 131-140, 2014.
- [28] W. Qiao, W. Zhou, J. M. Aller, and R. G. Harley, "Wind Speed Estimation Based Sensorless Output Maximization Control for a Wind Turbine Driving a DFIG," IEEE Transactions on Power Electronics, vol. 23, no. 3, pp. 1156-1169, 2008.
- [29] P. Krause, O. Wasynczuk, S. D. Sudhoff, and S. Pekarek, "Analysis of Electric Machinery and Drive Systems," 3rd Edition, Wiley-IEEE Press, 2013.
- [30] L. A. Zadeh, "Fuzzy Sets," Information and Control, vol. 8, no. 3, pp. 338-353, 1965.