

Smart Kitchen System Using IoT

Lalita Shravan udage

*Department of electronics and
telecommunication engineering
Deogiri institute of engineering and
management studies Aurangabad
Aurangabad, India*

Mr M. S. Badmera

*Department of electronics and
telecommunication engineering
Deogiri institute of engineering and
management studies Aurangabad
Aurangabad, India*

Abstract— *The smart kitchen automation system enhances safety and convenience by utilizing interconnected components. Power is derived from the main AC supply, converted to stable DC voltage for the ESP8266 Wi-Fi module and sensors. Acting as the central control unit, the ESP8266 interfaces with MQ-6 gas and temperature sensors to monitor environmental conditions and connects to Blynk Cloud for remote monitoring and control. Key actuators include a relay module for fan ventilation and a buzzer for audible alerts during emergencies. This system ensures timely responses to gas leaks and temperature changes, improving overall kitchen safety and efficiency. Integration with Blynk Cloud allows for real-time data transmission and remote management via a mobile app, making the system a comprehensive solution for smart kitchen automation. The development of this system addresses the lack of real-time monitoring and automated response in conventional kitchens, providing a robust solution for modern kitchen safety and efficiency through advanced IoT technology.*

Keywords— *MQ-6 sensor, ESP8266, Relay module, Fan, Temperature sensor.*

I. INTRODUCTION

In recent years, the concept of smart homes has gained significant attention due to advancements in technology and the growing demand for convenience and safety in household management. The kitchen, being a critical part of any home, has seen numerous innovations aimed at enhancing its functionality and safety. Smart kitchen systems incorporate various sensors, microcontrollers, and IoT (Internet of Things) technologies to automate and monitor kitchen activities. These systems not only enhance the user experience but also significantly reduce the risks associated with gas leaks, fire hazards, and inefficient energy usage. The integration of IoT allows for remote monitoring and control, providing users with real-time updates and the ability to respond promptly to potential issues. Traditional kitchens pose several safety risks, including gas leaks, fire hazards, and inefficient energy consumption. The lack of real-time monitoring and automated control systems can lead to dangerous situations, particularly when gas leaks go undetected or when high temperatures cause fires.

Furthermore, the inability to remotely monitor and control kitchen devices limits the effectiveness of safety measures. There is a need for an intelligent system that can continuously monitor environmental parameters, detect hazardous conditions, and automate responses to ensure safety and efficiency in the kitchen.

The scope of this project includes the design, development, and implementation of a smart kitchen automation and monitoring system. The system will incorporate various sensors, including gas and temperature sensors, to monitor the kitchen environment. An ESP8266 Wi-Fi module will be used as the central controller, interfacing with sensors and actuators and communicating with the Blynk Cloud for remote access. The project will also involve developing a mobile app for real-time monitoring and control. The system will be designed to automatically respond to hazardous

conditions by activating alarms and ventilation systems. The project will focus on ensuring reliability, accuracy, and ease of use.

The primary objectives of the smart kitchen automation and monitoring system are:

1. **Safety Enhancement:** Detect gas leaks and high temperatures to prevent potential hazards.
2. **Automation:** Automate the response to hazardous conditions, such as activating fans and alarms.
3. **Remote Monitoring and Control:** Provide users with the ability to monitor and control kitchen activities remotely via a mobile app.
4. **Energy Efficiency:** Optimize the usage of kitchen appliances to reduce energy consumption.
5. **User-Friendly Interface:** Develop an intuitive and user-friendly interface for easy interaction with the system.

II. LITRATURE SURVEY

2.1. The Hybrid Buck-Boost Converter Operating Principle Based on the Zeta topology, the circuit includes, as seen in Figure 1, two active power switches which are (S1 and S2), two diodes as (D1 and D2), two inductors which are (L1 and L2), two capacitors as (C1 and C0), and a load R0 as shows follows. The converter analysis has been simplified by making the following assumptions.

S r. N o.	Title	Author	Year & Publication	Focus Technology
1.	Design and construction of a GSM based gas leak Alert system	J. Tsado, O. Imoru, S.O. Olayemi	2014 IRJEEE Vol. 1(1)	GSM-based gas leak alert system
2.	A Development Platform for Integrating Wireless Devices and Sensors into Ambient Intelligence Systems	M. Eisenhauser, P. Rosengren, P. Antolin	2009 IEEE	Integration of wireless devices and sensors into ambient intelligence
3.	Vision and Challenges for Realizing the Internet of Things	S.T. Apeh, K.B. Eramseh, U.	April 2010 European Commission, Directorate - General for Communications Network	The state-of-the-art of IoT and presents the key technological drivers, potential applications, challenges and future research areas
4.	The Internet of	A. Do	2010 ITNG	IoT for ambient

	Things for Ambient Assisted Living	hr, R. Modre-Oprian, M. Drobits, D. Hayn, G. Schreier	Conference	assisted living
5.	Design and Development of Kitchen Gas Leakage Detection and Automatic Gas Shut off System	S.T. Apeh, K.B. Eramseh, U. Iruansi	2014 JETEAS	Gas leakage detection and automatic shut-off. Kitchen gas sensors
6.	Digitally Greenhouse Monitoring and Controlling of System based on Embedded System	K. Sahu, MSG Mazumdar	2015 IJSER	Green house monitoring and control. Embedded systems
7.	Development of Wireless Sensor Network System for LPG Gas Leakage Detection System	T.H. Mujawar, V.D. Bachuwar, M.S. Kasbe, A.D. Shaligram, L.P. Deshmukh	2015 IJSER	LPG gas leakage detection using WSN. Wireless Sensor Network
8.	Dangerous Gas Detection using an Integrated Circuit and MQ-9	A.S. Falohun, A.O. Oke, B.M. Abolaji	2016 IJCA	Dangerous gas detection using MQ-9
9.	Gas Leakage	Luay Fraiwan,	2011 IEEE	Home safety gas

	Detection system	Khaldon Lweesy, Aya Bani-Salma, Nour Mani		leakage detection
10.	GSM Based Low- cost Gas Leakage, Explosion and Fire Alert System with Advanced Security	Pritam Ghosh, Palash Kanti Dhar	2019 ECC E Co nferen ce	Gas leakage, explosion , and fire alert system

III. PROPOSED SYSTEM

The system comprises several blocks, each representing a different component or function of the smart kitchen automation system. The power supply is derived from the main AC supply, converted to a stable DC voltage to power the ESP8266 Wi-Fi module and other sensors. The ESP8266 serves as the central control unit, interfacing with sensors and actuators, and connecting to the Blynk Cloud for remote monitoring and control. The sensors used include the MQ-6 gas sensor and a temperature sensor, providing environmental data. Actuators like the relay module control the fan, and the buzzer provides an audible alert in case of a gas leak. The block diagram outlines the flow of power and data between these components.

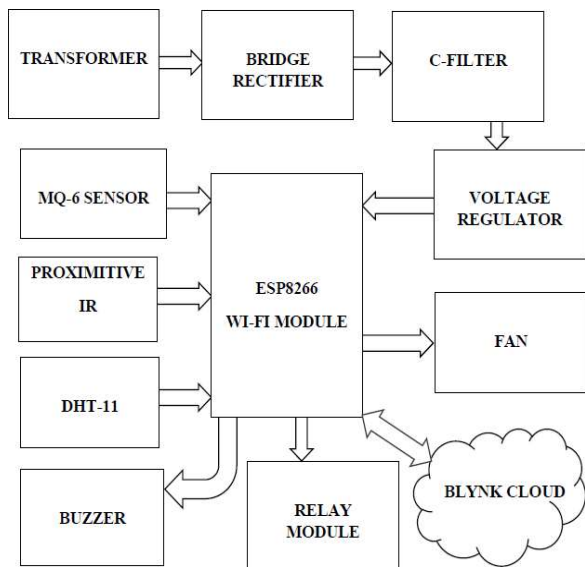

Fig.1: Block diagram

- **Transformer:** The transformer steps down the AC voltage from the main supply to a lower AC voltage suitable for the circuit.
- **Bridge Rectifier:** Converts the stepped-down AC voltage to pulsating DC voltage.
- **C-Filter:** This capacitor filter smooths the pulsating DC voltage from the bridge rectifier to produce a more stable DC voltage.
- **Voltage Regulator:** Ensures a consistent and regulated DC output voltage, which is necessary to power the ESP8266 Wi-Fi module and other components.
- **ESP8266 Wi-Fi Module:** This is the central microcontroller unit that manages data from sensors and controls actuators. It also connects to the Blynk Cloud for remote monitoring and control via the internet.
- **MQ-6 Sensor:** This gas sensor detects the presence of gases such as propane, butane, and methane. It sends signals to the ESP8266 if a gas leakage is detected.
- **Temperature Sensor:** Monitors the kitchen temperature and sends the data to the ESP8266 for analysis and action if needed.
- **Buzzer:** An alert device that sounds an alarm in case of gas leakage or other emergency conditions detected by the system.
- **Relay Module:** Controls high-power devices like the fan based on commands from the ESP8266. It acts as a switch, turning devices on or off as needed.
- **Fan:** Controlled by the relay module, the fan is turned on to ventilate the kitchen if high temperature or gas leakage is detected.
- **Blynk Cloud:** A cloud platform that allows remote monitoring and control of the system via a mobile app. The ESP8266 communicates with Blynk Cloud to send sensor data and receive control commands.

Flow chart

- Start
- Initialize Sensors and Wi-Fi
 - Initialize temperature sensor
 - Initialize gas sensor (e.g., MQ-6)
 - Connect to Wi-Fi
 - Connect to Blynk Cloud
- Read Sensor Data
 - Read temperature sensor data

- Read gas sensor data
- Check Temperature and Gas Levels
 - Compare temperature with threshold
 - Compare gas level with threshold
- Send Data to Blynk Cloud
 - Update temperature and gas readings on the Blynk mobile app
- Trigger Alerts (if necessary)
 - If temperature exceeds threshold, send alert
 - If gas level exceeds threshold, send alert
- Display Alerts on Blynk App
 - Display alert messages on the Blynk app
 - Visual indications (e.g., red alert button)
- Wait for Next Reading Interval
 - Wait for a predefined time interval
- Repeat from Step 3

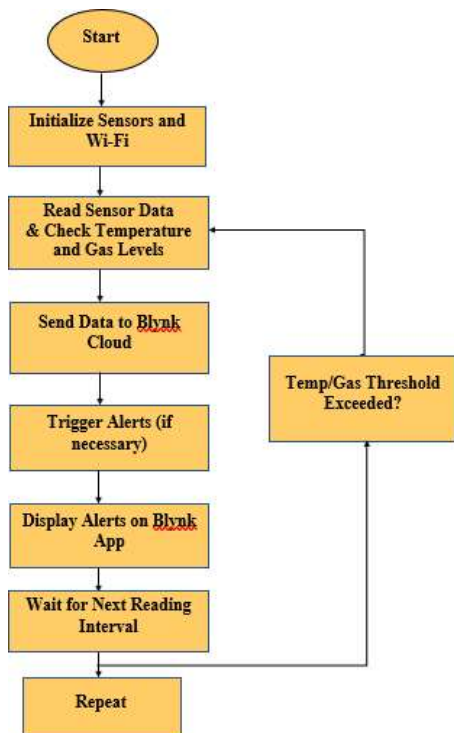

Fig.2: Flow chart

IV. RESULT & DISCUSSION

The system comprises several blocks, each representing a different component or function of the smart kitchen automation system. The power supply is derived from the main AC supply, converted to a stable DC voltage to power the ESP8266 Wi-Fi module and other sensors. The ESP8266 serves as the central control unit, interfacing with sensors and actuators, and connecting to the Blynk Cloud for remote monitoring and control. The sensors used include the MQ-6 gas sensor and a temperature sensor, providing environmental data. Actuators like the relay module control the fan, and the buzzer provides an audible alert in case of a gas leak. The block diagram outlines the flow of power and data between these components. The transformer steps down the AC voltage from the main supply to a lower AC voltage suitable for the circuit, which is then converted to pulsating DC voltage by the bridge rectifier. The capacitor filter smooths the pulsating DC voltage to produce a more stable DC voltage, while the voltage regulator ensures a consistent and regulated DC output necessary to power the ESP8266 and other components. The ESP8266 manages data from sensors and controls actuators, while also connecting to the Blynk Cloud for remote monitoring and control. The MQ-6 gas sensor detects gases such as propane, butane, and methane, sending signals to the ESP8266 if a gas leakage is detected. The temperature sensor monitors the kitchen temperature and sends data to the ESP8266 for analysis and action if needed. The buzzer sounds an alarm in case of gas leakage or other emergency conditions, while the relay module controls high-power devices like the fan, turning them on or off as needed. Controlled by the relay module, the fan ventilates the kitchen if high temperature or gas leakage is detected. The Blynk Cloud platform allows remote monitoring and control of the system via a mobile app, with the ESP8266 communicating to send sensor data and receive control commands.

- Quickstart Device: This indicates the name or label given to the device within the Blynk app.
- Green Dot: Indicates that the device is online and connected.
- Welcome Message: A large green display with the text "Welcome Smart Kitchen" indicates a successful initialization and readiness of the system.
- Temperature Gauge: Labelled "Temperature", this gauge shows the current temperature reading from the temperature sensor. The scale is from 0 to 1, which might be a simplified representation or a calibration setting.
- Gas Sensor Gauge: Labelled "Gas Sensor", this gauge shows the current gas level reading from the MQ-6 gas sensor. The scale is from 0 to 1, which might also be a simplified representation or a calibration setting.

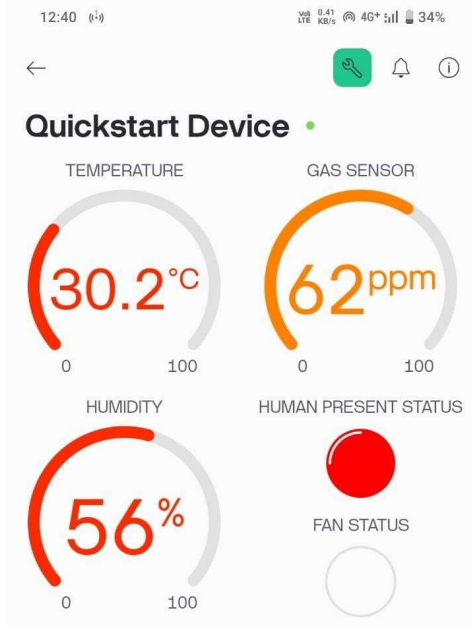

Fig.3: Mobile app (Welcome display, Alert for Human present and temperature)

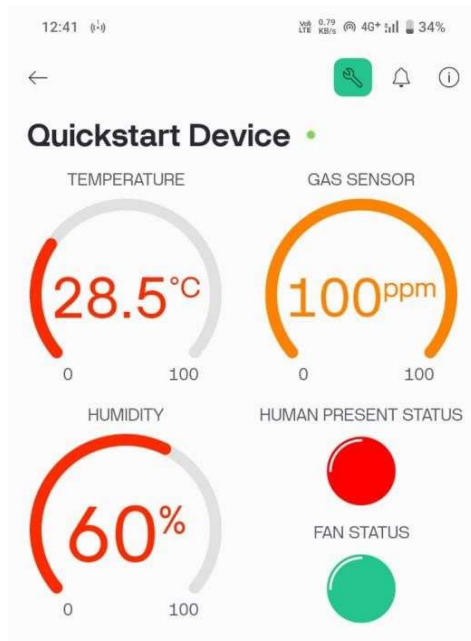

Fig.4: Mobile app (Welcome display, Alert for Human present and temperature)

The interface provides real-time data on temperature and gas levels, enabling users to monitor the kitchen environment continuously. Through the bell icon, users can receive alerts in case of abnormal readings (e.g., gas leaks). The Blynk app allows users to monitor and control the smart kitchen system remotely, enhancing convenience and safety. The wrench icon suggests that users can customize settings, possibly including sensor thresholds, notification preferences, and device behavior. This user interface effectively presents essential data for the smart kitchen system, ensuring users can monitor temperature and gas levels in real-time. The integration with the Blynk app allows for remote access, alerts, and customization, contributing to a safer and more convenient kitchen environment.

V. CONCLUSION

A smart kitchen automation and monitoring system that enhances safety and convenience by continuously monitoring gas levels and temperature using MQ-6 and temperature sensors. The ESP8266 Wi-Fi module processes sensor data and controls actuators like fans and buzzers, while integration with Blynk Cloud allows for remote monitoring and real-time alerts. This setup ensures a timely response to gas leakages and temperature changes, improving kitchen safety and efficiency. Future scope includes enhanced sensor integration, machine learning for predictive analysis, voice control, energy efficiency features, expanded automation, and user customization. Applications range from residential and commercial kitchens to industrial settings and smart homes. The system's advantages are improved safety, convenience, operational efficiency, real-time alerts, cost-effectiveness, and scalability, paving the way for advancements in home automation technology.

VI. REFERENCES

- [1] J. Tsado, O. Imoru, S.O. Olayemi, —Design and construction of a GSM based gas leak Alert system, IEEE Transaction., IRJEEE Vol. 1(1), pp. 002-006, September, 2014.
- [2] M. Eisenhauer, P. Rosengren, P. Antolin, —A Development Platform for Integrating Wireless Devices and Sensors into Ambient Intelligence Systems, pp.1-3.
- [3] Vision and Challenges for Realizing the Internet of Things, European Union 2010, ISBN 9789279150883.
- [4] A. Dohr, R. Modre-Oprian, M. Drobnics, D. Hayn, and G. Schreier, —The internet of things for ambient assisted living, | in Information Technology: New Generations (ITNG), 2010

Seventh International Conference on, 2010, pp. 804–809

- [5] Apeh S.T, Erameh K.B, Iruansi U., —Design and Development of Kitchen Gas Leakage Detection and Automatic Gas Shut off System. I, Journal of Emerging Trends in Engineering and Applied Sciences (JETEAS)5(3):222-228 (ISSN: 2141-7016) Scholarlink ResearchInstitute Journals, 2014.
- [6] Sahu K, Mazumdar MSG. (2012) Digitally Greenhouse Monitoring and Controlling of System based on Embedded System. International Journal of Scientific & Engineering Research, 3(1).
- [7] T.H Mujawar, V.D. Bachuwar, M.S. Kasbe, A.D. Shaligram and L.P. Deshmukh “Development of Wireless Sensor Network System for LPG gas Leakage Detection System” in International Journal of Science & Engineering Research, Vol. 6, Issue 4, ISSN 2229- 5518, April-2015
- [8] Falohun A.S, Oke A.O & Abolaji B.M “Dangerous Gas Detection using an Integrated Circuit and MQ-9” International journal of Computer Applications (0975-8887) vol 135. No 9 pp.30- 34, 2016.
- [9] Luay Fraiwan, Khaldon Lweesy, Aya Bani- Salma and Nour Mani “A wireless Home Safety Gas Leakage Detection system” in IEEE 2011 vol. 12 No 9 pp.11-14, 2011.
- [10]. “GSM Based Low-cost Gas Leakage, Explosion and Fire Alert System with Advanced Security” by Pritam Ghosh, Palash Kanti Dhar, International Conference on Electrical, Computer and Communication Engineering (ECCE), 9 February 2019.
- [11] L.P.G gas. Also, due to continue monitoring by IOT it possible for the owner to remotely check the status of gas levels and temperature in the kitchen.
- [12] “Automatic Smart and Safety Monitoring System for Kitchen Using Internet of Things” by Harika Pudugosula, Proceedings of the ghly reliable Smart Kitchen Security Alarm System Based on Internet of Things” by Yun Wang, Tong Zhou, 2018 3rd International Conference on Materials Science, Machinery and Energy Engineering.